

**GOTSCHLICH**

## Ecco 120 BE

The motor-driven man-height portal turnstile Ecco 180 BE with drum, deflection rack, guiding elements and stands in stainless steel is particularly suitable for outdoor plant security applications, as well as sports arenas, leisure facilities and pedestrian connections between car parks and office or residential buildings.

Due to its small overall size and its transparent appearance, Ecco 120 BE fits seamlessly in with fencing.

Ecco 120 BE is suited for unidirectional or bidirectional operation. With its 120° pitch, it offers high pedestrian comfort and good separating. For extremely cost-sensitive applications, a hot-galvanized version is available.

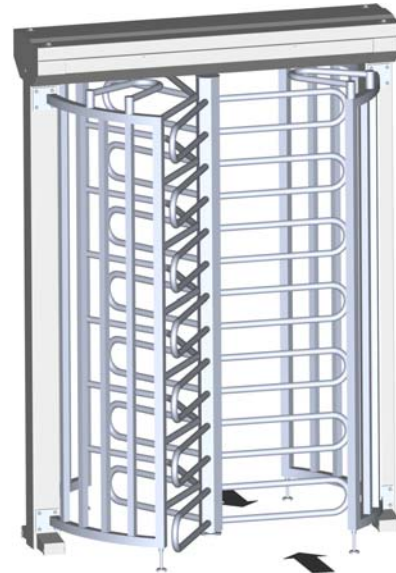

### Features

- Architecture-friendly Transparency
- Small Size
- Simple Mounting
- Vandalism Resistant
- Uni- or Bidirectional Operation
- Selectable Entrance Direction
- High Durability
- Integrated Electronic Control
- Maintenance-free Mechanism
- Transition Counts

### Application Areas

- Plant Security
- Sports and Leisure Facilities
- Car Parks

### Models/Options

- Portal turnstile with bails, 120° pitch, stainless steel
- Portal turnstile with bails, 180° pitch, hot galvanized

Options:

- Roofing with optional Eaves gutter and lighting
- Blocked at power-down



## Technical Characteristics

Power Supply:	230 V AC 50-60 Hz
Power Consumption:	50 VA max.
Operating Temperature:	-25°C to +40°C
Outer/Inner Width:	1.612 mm/640 mm
Length:	1.300 mm
Height:	2.250 mm
Weight:	230 kg
Reader Interface:	Floating Contacts
Material:	CrNi-Steel Type 1.4301 Aluminium, powder-coated

## Functional Description

In normal operation, an electric brake holds the drum in its blocking position.

Upon reception of a release signal from the reader system or an optional external manual control, the brake is released, allowing turning the drum in the preset direction.

Application of slight pressure triggers the driving motor, which turns the drum by 120°. Internal sensors prevent injuries from the turning bars running against the backs of passing pedestrians.

After completion of the transit, the turnstile sends a signal to the reader.

Powered off, the turnstile arms can be turned manually with little force.

The 120° pitch ensures high pedestrian and good separating of persons.

The design prevents climbing over the turnstile.

## Standards

CE	Directive of Machinery 98/37/ec
UL	94 V-0
VDE/ÖVE	protective earthing
Protection Class:	IP 43 / EN 60529
Production Standard:	ISO 9001

## Application Example (Plan View)

## Dimension Overview

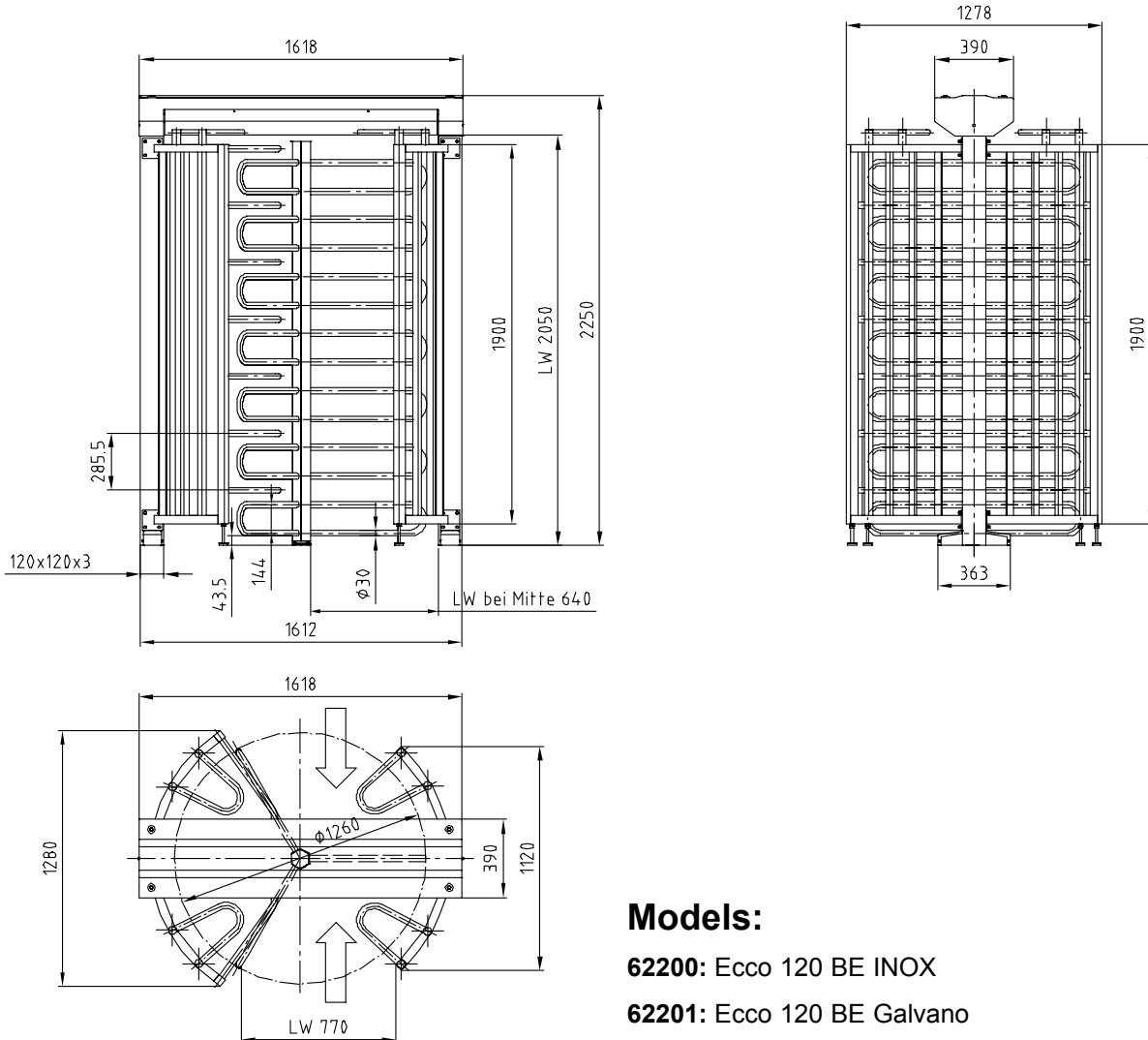

## Electrical Ports

### Input:

- Reader Release Entrance Direction
- Reader Release Exit Direction
- Manual Release Entrance Direction
- Manual Release Exit Direction
- Permanent Release Entrance Direction
- Permanent Release Exit Direction
- Stop Button

### Output:

- External Counter non-resettable Entrance
- External Counter non-resettable Exit
- External Light
- Feedback

## Models:

**62200:** Ecco 120 BE INOX

**62201:** Ecco 120 BE Galvano

## Extras & Options:

Foundation Assembly with Template

Reader Mounting Fee including holder

Roof 1,300 mm length

Eaves gutter for roof

Inner ceiling with lighting

**61950:** External console

**22000:** Blocked at power-down

## Suitable By-Products:

**62212:** Ecco 120 BD Twin Turnstile

**21695:** Reader Stand



## Sample Tender Document Entry

Pos.	Qty.	Text	Unit Price	Total
		<p>pcs. vertical turnstile(s), man-high, with motor-driven turnstile drum. Blocking device bails with 120° pitch.</p> <p>Blocking device, deflection rack, guiding element and stand in V2A stainless steel, matt finished or sanded and coated with acid protection. Bridge hot-galvanized steel, plastic coated.</p> <p>Gearbox cover Aluminium powder-coated RAL 9006 White Aluminium.</p> <p>Maintenance-free drive</p> <p>Power supply and electronic control for bidirectional operation integrated in the turnstile. Drive and drive electronics mounted overhead.</p> <p>230 V AC 50 Hz operation</p> <p>Prepared for physical and electrical attachment of card readers or biometric access control devices on both sides.</p> <p>Screw mounting, direct on sustainable floors (e.g. concrete foundation) or with optionally available mounting brackets on non-sustainable floors.</p> <p>Reference product: Gotschlich Ecco 120 BE INOX</p> <p>alternatively:</p> <p>pcs. vertical turnstile(s), as described above, guiding element, bridge and stands hot-galvanized steel</p> <p>Reference product: Gotschlich Ecco 120 BE Galvano</p> <p>with the following accessories:</p> <p><input type="checkbox"/> External console for manual operation</p>		